

PROBEAM®

BY CUSTOM DYNAMICS®

ProBEAM® Saddlebag LED Lights Installation Instructions

We thank you for purchasing the Custom Dynamics® ProBEAM® Saddlebag LED Lights. Our products utilize the latest technology and highest quality components to ensure you the most reliable service. We offer one of the best warranty programs in the industry and we back our products with excellent customer support. If you have questions before or during installation of this product please call Custom Dynamics® at 1(800) 382-1388.

Part Numbers: PB-SB-BCM-BR PB-SB-BCM-BS
PB-SB-BCM-CR PB-SB-BCM-CS

US Patent: D875977, D876,691S
China Patent: ZL201 930037082.0

Package Contents:

- Saddle Bag LED Light W/ Quick Disconnect Harness (2)
- BCM Y Harness Adapter w/ Plugs (1)
- Adhesive Primer (1)
- 4" Tie Wraps (10)
- Cable Tie Holders (6)

Fits: 2014-2020 Street Glide, Street Glide Special, Electra Glide Ultra Classic & Ultra Limited 2015-2016 Ultra Classic Low, 2015-2020 Road Glide, Road Glide Special, Ultra Limited Low, 2017-2020 Road King Special, 2016 CVO™ Road Glide Ultra, 2016-2020 Road Glide® Ultra, and CVO™ Limited - Functions as Run/Brake/Turn

2014 CVO™ Road King, 2015-2020 CVO™ Street Glide, and 2018-2020 CVO™ Road Glide - Functions as Run/Turn unless BCM has been reprogrammed for Run/Brake/Turn

2014-2020 Road King Standard, 2014-2015 CVO™ Limited, and 2015 CVO™ Road Glide Ultra 2019-2020 Electra Glide Standard- Functions as Run/Turn



Installation:

1. Test fit the Saddle Bag Lights, on each bag. The light should mount a couple millimeters below the bottom edge of the lid when the lid is closed. Mark the location with a grease pencil.
2. Clean the surface area location with alcohol and apply the adhesive primer. Allow 1-2 minutes to dry.
3. Remove the red adhesive backing and install the lights on the left and right saddle bags. Press firmly into place.
4. Remove both bags from the bike.
5. Clean the surface area locations for the tie wrap holders with alcohol; apply the adhesive primer and allow to dry. Remove paper backing from cable tie holders and press into place (See Picture 1).
6. Route wires from bag light to each tie wrap holder location and secure with enclosed tie wraps.
7. Remove seat from bike and locate rear main wire harness.
8. Plug BCM Y harness adapter into rear wiring harness.
9. Route the wires on the harness adapter out from under the seat and towards saddle bags.
10. Reinstall saddle bags. Connect 3 pin plugs from bag lights to Y adapter making sure female with purple wire plugs in male with purple wire, and female with brown wire plugs into male with brown wire. (See different configurations on page 2)
11. Secure wires with the included tie wraps, make sure wiring will not come in contact with moving parts or in an area with high heat. Also take care that wires will not get pinched or frayed then reinstall seat.
12. Perform a BCM sync by turning key on, turn 4 way hazards on, turn key off. Allow hazards to run for 3-4 minutes. Turn Key on, Turn Hazards off, Turn Key off.
13. Test operation of running, brake and turn signal lights.

BAGZ™ come with plug and play weatherproof quick disconnect to make future removal of saddlebags quick and easy (see pictures below).



⚠ ATTENTION ⚠

Disclaimer: Removal of our saddlebag lights after installation, may cause permanent damage to the finished surface area of the saddlebag.

Warning: Disconnect negative battery cable from battery; refer to owner's manual. Failure to do so may result in electrical shock, injury or fire. Secure negative battery cable away from positive side of battery and all other positive voltage sources on vehicle.

Safety First: Always wear appropriate safety gear including safety glasses when performing any electrical work. It is highly recommended that safety glasses be worn throughout this installation process. Be sure vehicle is on level surface, secure and cool.

Important: This product is designed and intended for use as auxiliary lighting only. It is NOT intended to replace any original equipment lighting installed on the vehicle and should not be used for that purpose. This product must be wired so that it does not interfere with any original equipment lighting.

Note: The Y Harness Adapter must be plugged into the output (behind) any brake strobe modules.



Questions? Call us at: 1 (800) 382-1388 M-TH 8:30AM-5:30PM / FR 9:30AM-5:30PM EST

Installation Instructions - Page 2

Original Configuration

Functions listed on page 1

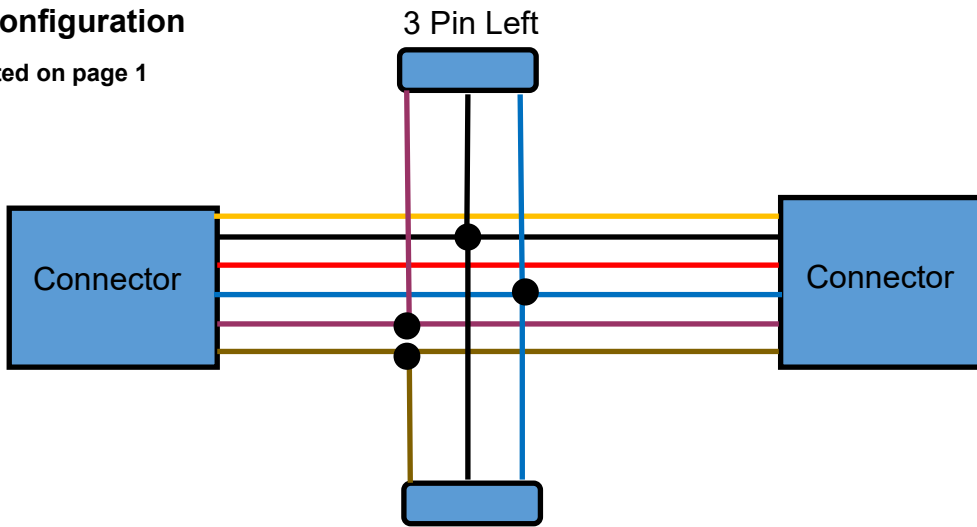

Run-Brake Modification

For 2014 CVO™ Road King, 2015-2019 CVO™ Street Glide, 2018-2019 CVO™ Road Glide, 2014-2019 Road King® Standard, 2014-2015 Limited CVO™ & 2015 Road Glide Ultra CVO™

*Purple and Brown Wires going from the 3 Pin Connectors to the Y Harness must be cut and moved from the Purple and Brown to the Red

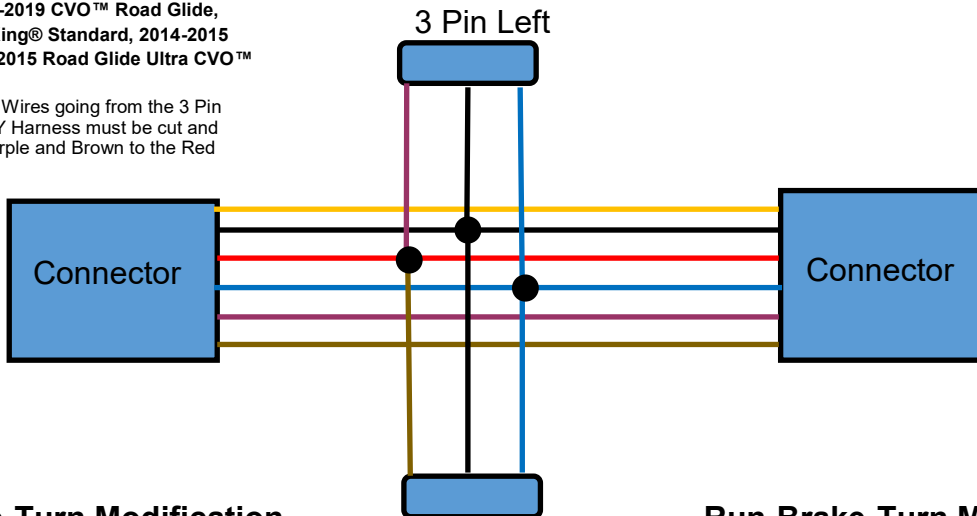

Run-Brake-Turn Modification

For 2014-2019 Road King® Standard, 2014-2015 Limited CVO™ & 2015 Road Glide Ultra CVO™

*Run-Brake-Turn controller (SMART Triple Play®) required. Blue wires going to the 2 three pin connectors must be cut and capped off.

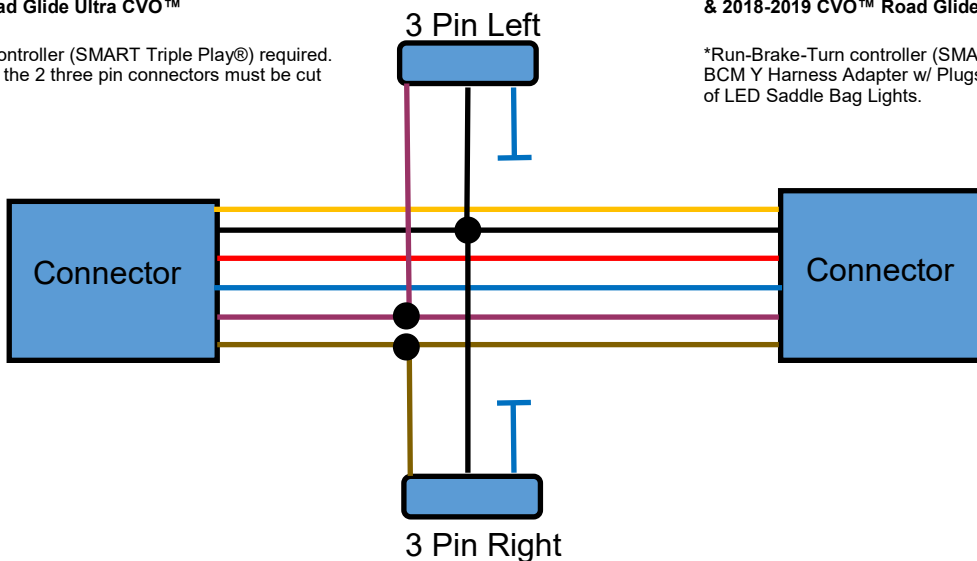

Run-Brake-Turn Modification

For 2014 CVO™ Road King, 2015-2019 CVO™ Street Glide & 2018-2019 CVO™ Road Glide

*Run-Brake-Turn controller (SMART Triple Play®) required. BCM Y Harness Adapter w/ Plugs not required for installation of LED Saddle Bag Lights.

Questions? Call us at: 1 (800) 382-1388 M-TH 8:30AM-5:30PM / FR 9:30AM-5:30PM EST