

## Items Supplied >

- 1 - Front Head Pipe
- 1 - Rear Head Pipe
- 2 - Heat Shields
- 1 - Muffler Mounting Bracket
- 2 - Mufflers
- 1 - Hardware Kit
- 2 - Muffler Gauges

## Application(s) >

YAMAHA V-STAR 1100 99-09

## Instruction Manual >

2767/2967

Page 1 of 2

**PRIOR TO INSTALLATION, MAKE SURE YOUR STOCK GASKETS ARE IN GOOD SHAPE. IF YOU HAVE ANY DOUBTS AS TO THEIR CONDITION, REPLACE THEM.**

1. Remove the two bolts holding the drivers right footpeg/floorboard assembly to the frame.
2. Remove the two zip ties that hold the rear brake reservoir hose and rear brake light switch wire to the frame being careful not to damage the wire or hose.
3. Unbolt the rear brake master cylinder reservoir and cover from the stock bracket setting the stock bolt aside for future reassembly.
4. Remove the stock Exhaust System setting the stock exhaust flange nuts aside for future reassembly.
5. Remove the stock muffler mounting bracket located at the rear of the frame.
6. Attach the bent end of the supplied master cylinder relocation bracket to the stock rear brake reservoir bracket using the stock bolt (see figure 1).

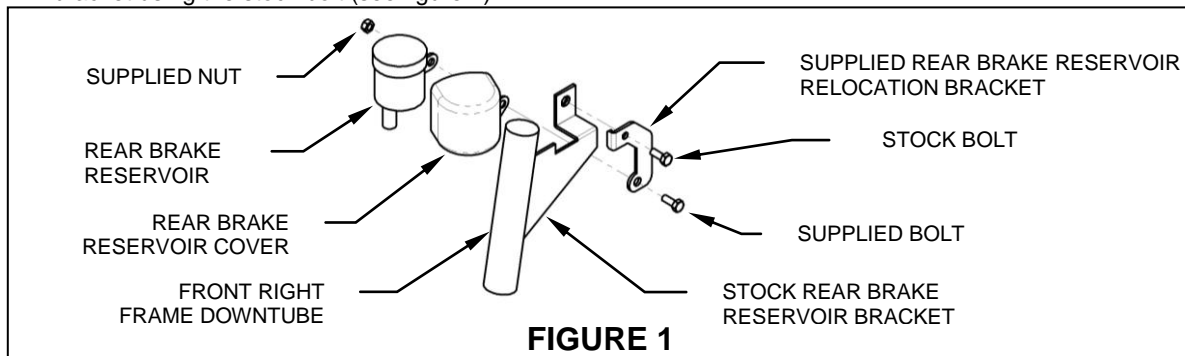
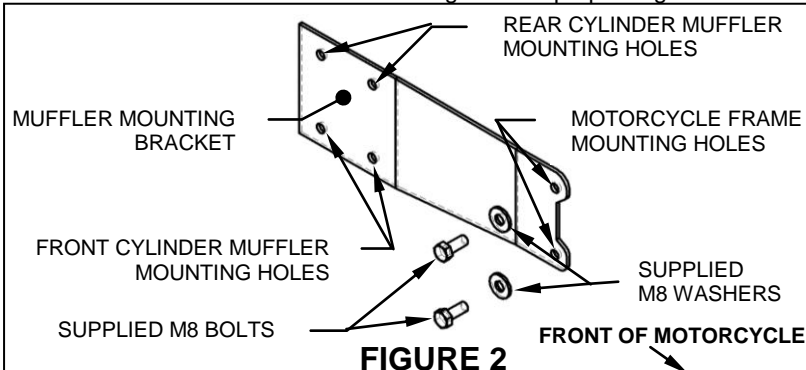

**FIGURE 1**

7. Attach the reservoir and cover to the backside of the supplied reservoir bracket using the supplied M6 bolt and nylock nut.
8. Attach the rear brake reservoir hose and brake light switch wire to the frame down tube with the supplied zip tie so they don't interfere with the cobra exhaust system.
9. Install the supplied muffler mounting bracket where the stock muffler bracket was located using the supplied M8 bolts and M8 washers (see figure 2)
10. Slide one supplied exhaust flange onto each head pipe.
11. Install the front and rear head pipes to the motor using the stock nuts. **DO NOT TIGHTEN**

**\* Cobra recommends you always wear a helmet while riding. Please never operate your motorcycle while under the influence of alcohol and/or drugs. Enjoy the new look of your motorcycle and please ride safely.**

12. Locate the two slider brackets, they have the cobra logo on them, in the hardware kit. Place one slider bracket inside each muffler bracket with the flat side of the slider bracket against the muffler bracket.
13. Slide one supplied clamp part #2761MSC onto each muffler. Refer to Figure 3 for proper alignment.
14. Slide one muffler onto the front head pipe and bolt into place through the supplied muffler bracket using the supplied 5/16 bolts (see figure 2). **DO NOT TIGHTEN**
15. Slide the other muffler onto the rear head pipe and bolt into place through the supplied muffler bracket using the supplied 5/16 bolts (see figure 2). **DO NOT TIGHTEN**



16. Locate the two cardboard muffler gauges and place them between the mufflers to help hold the mufflers parallel. (Refer to Figure 4). Make sure the mufflers are even on the exit end and the mounting bracket is in the middle of the muffler brackets and finger tighten the bolts.
17. Unscrew the five hose clamps and feed the tail end of the clamp through the clips on the inside of the heat shields. The screw end of the hose clamp should be accessible for tightening but not visible when the heat shields are mounted to the pipes.
18. Place the heat shields onto the head pipes and align on mufflers. You may need to loosen the muffler bolts to adjust the position of the muffler so that the heat shields fits tightly against the muffler (see figure 3). Snug the heat shield clamps into place but **DO NOT TIGHTEN**. Rotate the muffler clamp so it doesn't interfere with the heat shield but is still accessible to tighten (see figure 3).

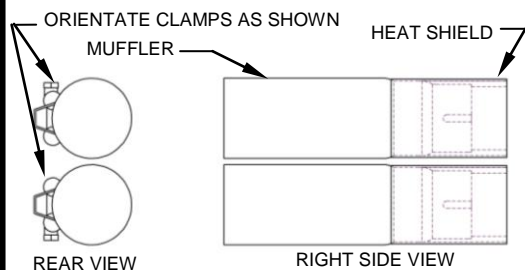

FIGURE 3

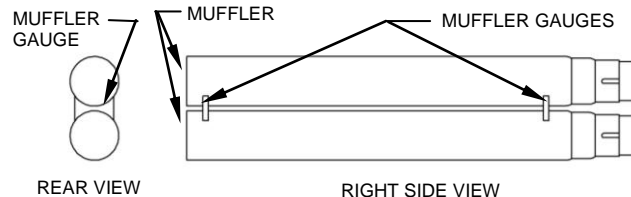

FIGURE 4

19. Make sure the system is properly aligned and mufflers are parallel.
20. Tighten the muffler clamps. Now, tighten the head pipes making sure to tighten evenly. **(NOTE: If the muffler clamps are slid to far up on the muffler or past the three slots, the clamps will not tighten.)**
21. Tighten the muffler mounting bracket to the frame, mufflers to the muffler mounting bracket and heat shields to exhaust pipes.
22. Reinstall footpeg/floorboard assembly with the stock bolts and tighten.
23. Remove cardboard gauges and torque all hardware to appropriate value before starting your motorcycle.

**IMPORTANT:** It is recommended that you re-jet your bike with a Cobra Jet Kit, available from Cobra part #92-2170. **Before starting your engine remove all fingerprints from chrome with a quality wax or chrome polish. Failure to do so can cause discoloration. Due to fluctuations in carburetor settings, timing, etc., Cobra Engineering does not warrant against chrome discoloration.**

California does not allow the use of aftermarket exhaust systems that remove original equipment catalysts, (except for racing use only) unless the Air Resources Board has issued an Executive Order for that system.